

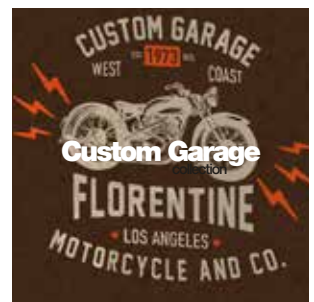

stifflex[®]
MADE IN ITALY

2023 SELECTION





stifflex[®]
MADE IN ITALY

An innovative system patented by Giuliano Mazzuoli, the designer and founder of the company, is at the foundation of the new **Stifflex** collections that are born from the talent and the creativity of a number of young graphic designers who by giving a free outlet to their fantasies have conceived the covers for the new collections of notebooks in the *Urban*

Series, Vintage Surfing, Surfside, Art, Calaca, Scrubbles, Underground, Cocktail, Camouflage, Historical Notes, Pop, Campbook, Fluo Love, Fluo Marilyn, Wild Pearl, Mrs. Crocodile, Animals Smile, Flora, New Fresh Fruit, Custom Garage, Gasoline, Container Notes, The Wall, Alias, VHS, Musicassette, Vinyl, Diversity, Sweet, Paint, PRISMA Colors and artWORK collections.



▶ Hard/flexible cover

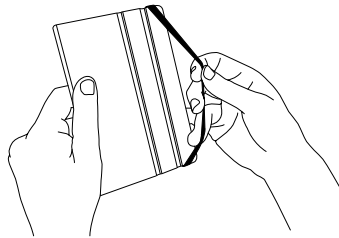

▶ Elastic closure

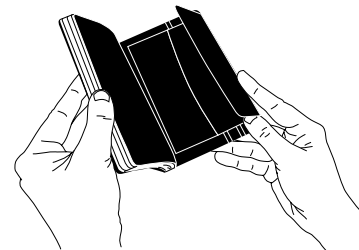

▶ Pocket/Bookmark



▶ Document holder pocket



▶ Bookmark



Every notebook comes with a ruler/bookmark

FORMATS

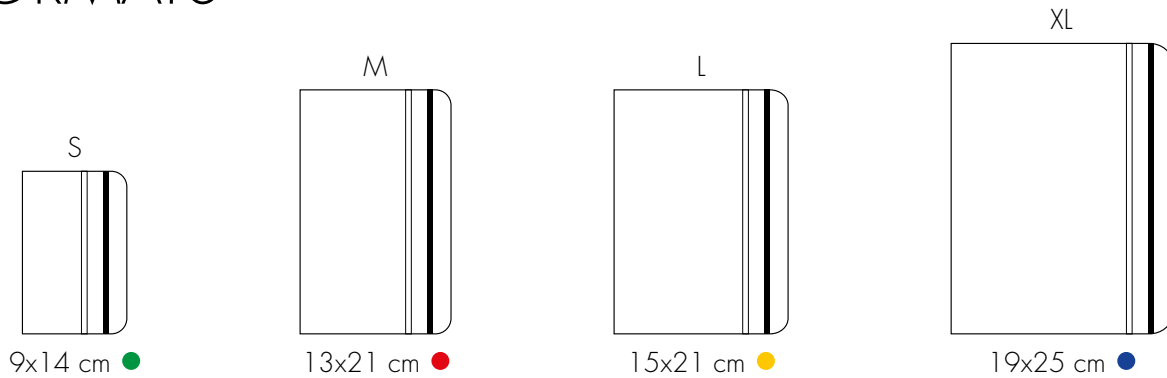

The notebooks are made with uncoated ivory-colored paper of 80 g. in the 9x14 cm, 13x21 cm, 15x21 cm and 19x25 cm formats.

- 9x14 cm: comprised of 144 pages of which 96 are lined, 32 are blank, and 16 are graphed.
- 13x21 cm 15x21 cm, 19x25 cm: comprised of 192 pages of which 144 are lined, 32 are blank, and 16 are graphed.

The graphed pages are perforated and easily detachable.

The product is certified FSC[®].

DISPLAYS

The *Stifflex* displays are supplied already assembled and are made in alveolar cardboard in a havana brown color so that the entire production maintains unaltered the standards of environmental sustainability and respect for the environment in which the company as always based its policies.



EXPO1 S

Counter display (9x14 cm)

Measurements: cm 34x29x27

It can contain: 36 pieces, 9x14 cm



EXPO2 M

Counter display (13x21 cm and/or 15x21 cm)

Measurements: cm 52x29x34

It can contain: 36 pieces, 13x21 cm and/or 15x21 cm



EXPO3 L

Floor display

Measurements: cm 60x25x185

It can contain: 100 pieces, 9x14 cm
60 pieces, 13x21 cm
40 pieces 15x21 cm
30 pieces 19x25 cm
230 assorted pieces in total



ALIAS



ALIAS



ALIAS

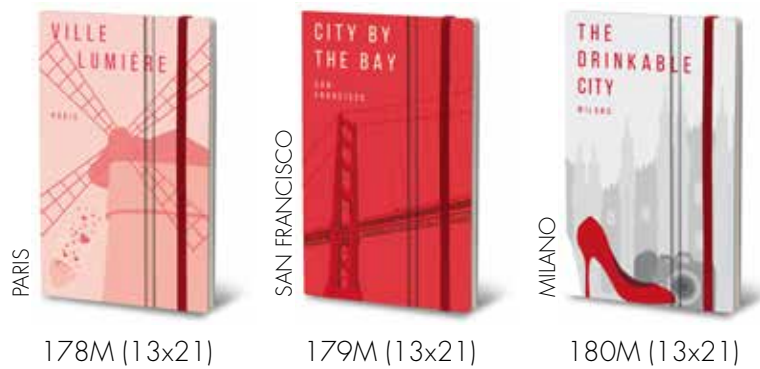

ART



VAN GOGH

196S (9x14)
196M (13x21)



KLIMT

197S (9x14)
197M (13x21)



MIRÓ

198S (9x14)
198M (13x21)



HOPPER

199S (9x14)
199M (13x21)

ART



MUNCH

200S (9x14)
200M (13x21)



KANDINSKY

201S (9x14)
201M (13x21)



PICASSO

202S (9x14)
202M (13x21)



RENOIR

203S (9x14)
203M (13x21)

ART



MAGRITTE

115S (9x14)
115M (13x21)



BOTTICELLI

116S (9x14)
116M (13x21)

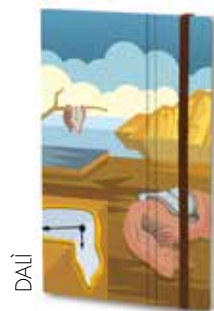

DALÍ

117S (9x14)
117M (13x21)



HARING

231M (13x21)



ART



BASQUIAT

232M (13x21)



WARHOL

233M (13x21)



POLLOCK

234M (13x21)



SCHIELE

235M (13x21)

STIFFLEX COLLECTIONS | 7

ART



ANGEL LISA

021S (9x14)
021M (13x21)



DEVIL LISA

022S (9x14)
022M (13x21)

New!



BANKSY

244M (13x21)

New!

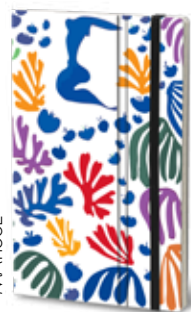

MATISSE

245M (13x21)

CONTAINER NOTES



YELLOW

162M (13x21)



BLUE

163M (13x21)



RED

164M (13x21)



GREEN

165M (13x21)

POP

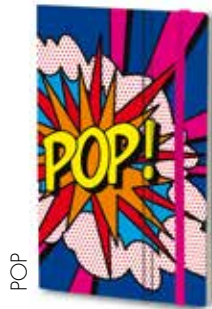

POP

130S (9x14)
130M (13x21)



WHITE LIPS

131M (13x21)



BLACK LIPS

132M (13x21)



WOW

133S (9x14)
133M (13x21)

POP



SPACESHIP

037M (13x21)



I LOVE YOU!

038S (9x14)
038M (13x21)



WOMAN

039S (9x14)
039M (13x21)



MIX

040M (13x21)

POP



ZOOM

041M (13x21)



BOOOOOOM!

042M (13x21)

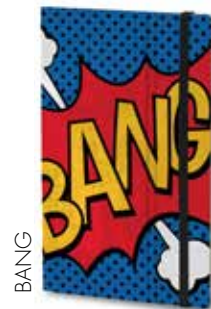

BANG

043S (9x14)
043M (13x21)



CAMPBOOK



DRAWINGS AND NOTES

134S (9x14)
134M (13x21)



SKETCHES AND IDEAS

135S (9x14)
135M (13x21)

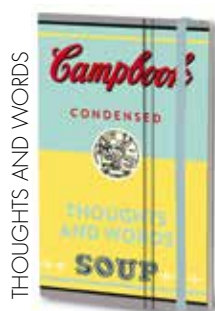

THOUGHTS AND WORDS

136S (9x14)
136M (13x21)

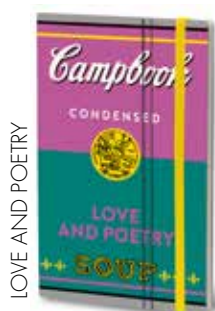

LOVE AND POETRY

137S (9x14)
137M (13x21)



FLUO LOVE



FUCHSIA

138M (13x21)



YELLOW

139M (13x21)



WHITE

140M (13x21)



FLUO MARILYN



GREEN - BLUE

159M (13x21)



YELLOW - GREEN

160M (13x21)



ORANGE - FUCHSIA

161M (13x21)



THE WALL (Test The Rest)



166S (9x14)
166M (13x21)



167S (9x14)
167M (13x21)



168S (9x14)
168M (13x21)

THE WALL (Fraternal Kiss)



169S (9x14)
169M (13x21)



170S (9x14)
170M (13x21)



171S (9x14)
171M (13x21)

ANIMALS SMILE



044M (13x21)



045M (13x21)



046M (13x21)



URBAN SERIES



NEW YORK CITY

093M (13x21)



MANHATTAN

094M (13x21)



BROOKLYN

095M (13x21)



TESTACCIO

096M (13x21)

URBAN SERIES



BRERA

097M (13x21)



GINZA

098M (13x21)



MARAIS

099M (13x21)



CAMDEN TOWN

100M (13x21)

ANIMALS SMILE



RABBIT

047M (13x21)



ELEPHANT

048M (13x21)



PENGUIN

049M (13x21)

VHS



VHS

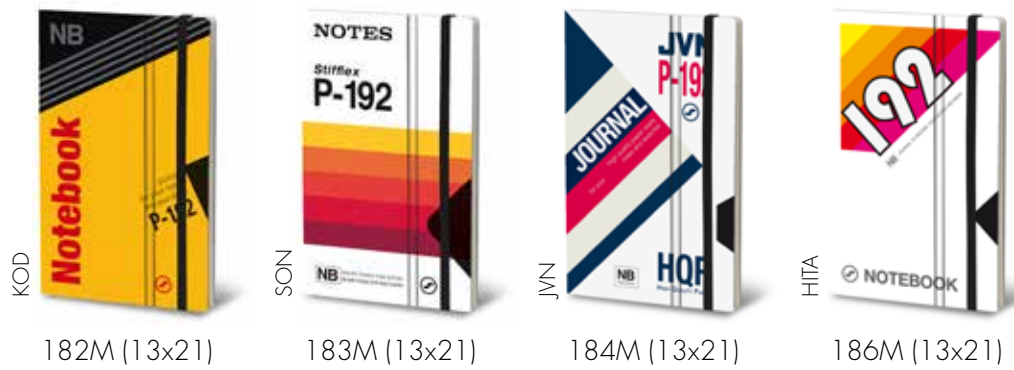

VINYL - 45 r.p.m.





MUSICCASSETTE



YELLOW TAPE

188S (9x14)



ORANGE TAPE

189S (9x14)



RED TAPE

190S (9x14)



BLUE TAPE

191S (9x14)

MUSICCASSETTE



BLACK HQP

192S (9x14)



BLACK CASSETTE

193S (9x14)



BLACK STEREO

194S (9x14)



BEIGE TAPE

195S (9x14)

VINYL - 33 r.p.m.

JAZZ NOTEBOOK



240XL (19x25)

CLASSIC NOTEBOOK



241XL (19x25)

LYRICS NOTES



242XL (19x25)

ABBEY NOTEBOOK



243XL (19x25)

UNDERGROUND - New York

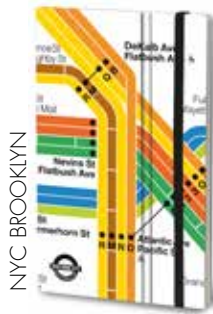

NYC BROOKLYN

123S (9x14)
123M (13x21)

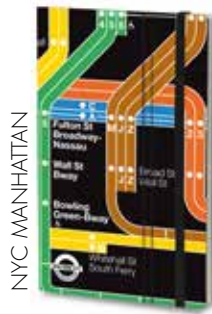

NYC MANHATTAN

124S (9x14)
124M (13x21)



NYC VINTAGE

125S (9x14)
125M (13x21)

UNDERGROUND



STOCKHOLM

056S (9x14)
056M (13x21)
056XL (19x25)



BERLIN

057S (9x14)
057M (13x21)
057XL (19x25)

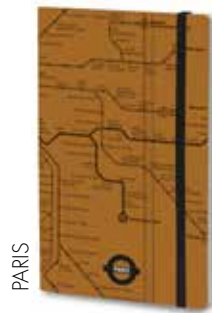

PARIS

058S (9x14)
058M (13x21)
058XL (19x25)

UNDERGROUND



MADRID

059S (9x14)
059M (13x21)
059XL (19x25)



LONDON

060S (9x14)
060M (13x21)
060XL (19x25)

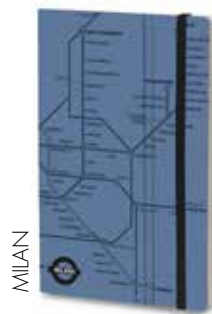

MILAN

061S (9x14)
061M (13x21)
061XL (19x25)



SURFSIDE



SUNSET

111M (13x21)



BLUE WAVE

112M (13x21)



RED WAVE

113M (13x21)



SUNRISE

114M (13x21)

CALACA



YELLOW

118S (9x14)
118M (13x21)



AGUAMARINE

119S (9x14)
119M (13x21)



LIGHT GREY

120M (13x21)

CALACA



INDIGO

053M (13x21)



CHARCOAL

054M (13x21)



FUCHSIA

055S (9x14)
055M (13x21)

HISTORICAL NOTES



I have a dream (USA)

025S (9x14)
025M (13x21)



God save the Queen (UK)

026S (9x14)
026M (13x21)



Dasvidania Tovarish (URSS)

027M (13x21)



Hasta la victoria siempre! (CUBA)

028M (13x21)

HISTORICAL NOTES



"It always seems impossible until it's done" (SOUTH AFRICA)

029M (13x21)



万歳！ Banzai！ (JAPAN)

030M (13x21)

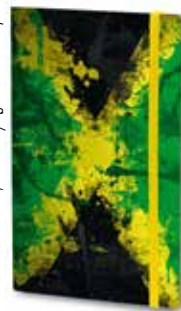

No woman, no cry (JAMAICA)

031M (13x21)



Brasil 10 (BRASIL)

032M (13x21)

HISTORICAL NOTES



Les couleurs de la liberté (FRANCE)

033M (13x21)



Italians do it better (ITALY)

034M (13x21)



Free Tibet (TIBET)

035M (13x21)



Jolly Roger (PIRATES)

036M (13x21)



HISTORICAL NOTES



Eendracht maakt macht -
L'union fait la force (BELGIUM)

101M (13x21)



Alba an Àigh (SCOTLAND)

102M (13x21)



Vamos, vamos Argentina
(ARGENTINA)

103M (13x21)



Du gamla, du fria (SWEDEN)

104M (13x21)

HISTORICAL NOTES



At Rejse er at leve (DENMARK)

105M (13x21)



A vivir que son dos días (SPAIN)

106M (13x21)



Ut på tur, aldri sur (NORWAY)

107M (13x21)

HISTORICAL NOTES



Einigkeit und Recht und Freiheit
(GERMANY)

108M (13x21)



Landi elds og ísa (ICELAND)

109M (13x21)



Ik zal handhaven (NETHERLANDS)

110M (13x21)

NEW FRESH FRUIT



PINEAPPLE

074L (15x21)

PEACH

075L (15x21)

STRAWBERRY

076L (15x21)

NEW FRESH FRUIT



TANGERINE

077L (15x21)

COCONUT

078L (15x21)

PASSIONFRUIT

079L (15x21)

DIVERSITY



NÍ HÁO

204L (15x21)

OLÁ

205L (15x21)

CIAO

206L (15x21)

HI

207L (15x21)



FLORA



ANEMONE

153S (9x14)
153L (15x21)
153XL (19x25)



POPPY

154S (9x14)
154L (15x21)
154XL (19x25)



HELLEBORE

155S (9x14)
155L (15x21)
155XL (19x25)



FLORA



ROSE

156S (9x14)
156L (15x21)
156XL (19x25)



CHRYSANTHEMUM

157S (9x14)
157L (15x21)
157XL (19x25)



JASMINE

158S (9x14)
158L (15x21)
158XL (19x25)



SWEET



POPSICLE

208L (15x21)



CANDY

209L (15x21)



CUPCAKE

210L (15x21)



DONUTS

211L (15x21)





stiff-basic®

MADE IN ITALY

We made the **Stiff-Basic** as an alternative to the *Stifflex* collection. The line is 100% Made in Italy just like all of our products, and the objective of the line is to offer a notebook at an entry-level price while maintaining the high-level quality of the manufacturing and the materials our products are known for.

FORMATS

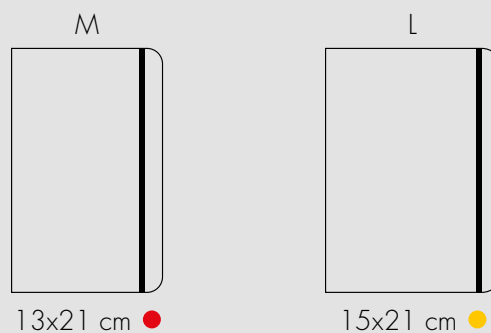

Two formats: 13x21 cm and 15x21 cm. A vast range of attractive covers that are ideal for all consumer targets. Made with high-quality uncoated white paper with a high opacity (that contrasts the transparency effect) and a smooth surface that is suited for all writing techniques, dry as well as wet. The notebook has a hardcover, and inside are 144 lined pages. The other technical aspects remain the same: an elastic closure and a pocket/bookmark. Just like the rest of our production, *Stiff-Basic* is also certified FSC®.

ART / BASIC

Ruled sheets



VAN GOGH

196MB (13x21)



KLIMT

197MB (13x21)

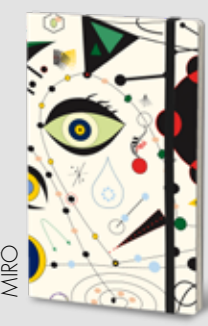

MIRÓ

198MB (13x21)



BANKSY

244MB (13x21)

ART / BASIC

Ruled sheets

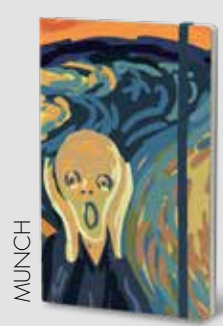

MUNCH

200MB (13x21)



KANDINSKY

201MB (13x21)



PICASSO

202MB (13x21)



MATISSE

245MB (13x21)

ART / BASIC

Ruled sheets



MAGRITTE

115MB (13x21)



BOTTICELLI

116MB (13x21)

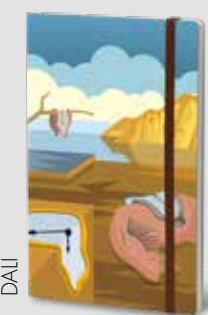

DALÍ

117MB (13x21)

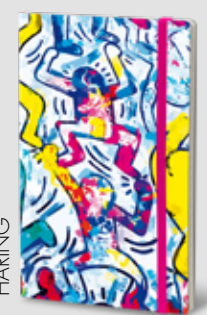

HARING

231MB (13x21)

ART / BASIC



Ruled sheets



BASQUIAT

232MB (13x21)



WARHOL

233MB (13x21)



POLLOCK

234MB (13x21)

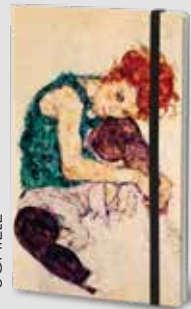

SCHIELE

235MB (13x21)

POP / BASIC



Ruled sheets



POP

130MB (13x21)



WOW

133MB (13x21)

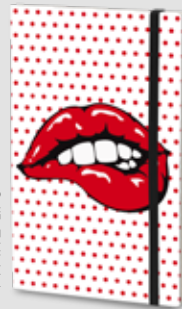

WHITE LIPS

131MB (13x21)



MIX

040MB (13x21)

CAMPBOOK, BLACK, RED / BASIC



Ruled sheets

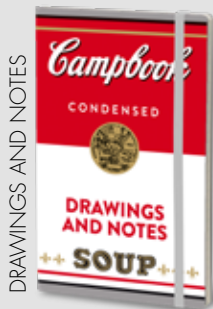

DRAWINGS AND NOTES

134MB (13x21)

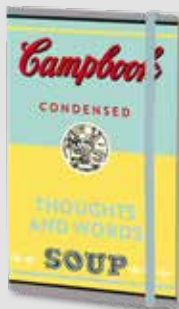

THOUGHTS AND WORDS

136MB (13x21)



BLACK

0R001MB (13x21)



RED

0R002MB (13x21)

VHS / BASIC

Ruled sheets



181MB (13x21)



182MB (13x21)



183MB (13x21)

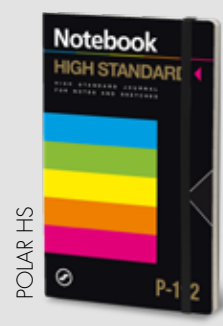

187MB (13x21)

VINYL - 45 r.p.m. / BASIC

Ruled sheets



236LB (15x21)



237LB (15x21)



238LB (15x21)



239LB (15x21)

SWEEP / BASIC

Ruled sheets



208LB (15x21)



209LB (15x21)



210LB (15x21)

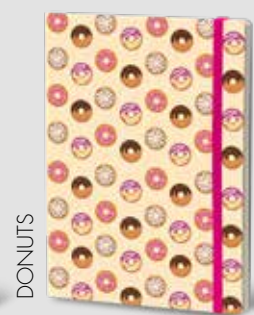

211LB (15x21)

The name for the new **Stiff** collection, with its essential and harmonious design, comes from the shortening of the name *Stifflex*. It's a more classic version of our notebook that enhances the value of tradition and enriches it with new elements. A hard cover with a balanced shade and the inside pages either blank or lined are combined with an environmentally friendly pencil with an eraser made with recycled and recyclable material. Available in the *Basic* and *Leatherlike* collections, the notebooks in this line adapt perfectly to every occasion and above all are perfect for those who enjoy habits that respect values from other times.

FORMATS

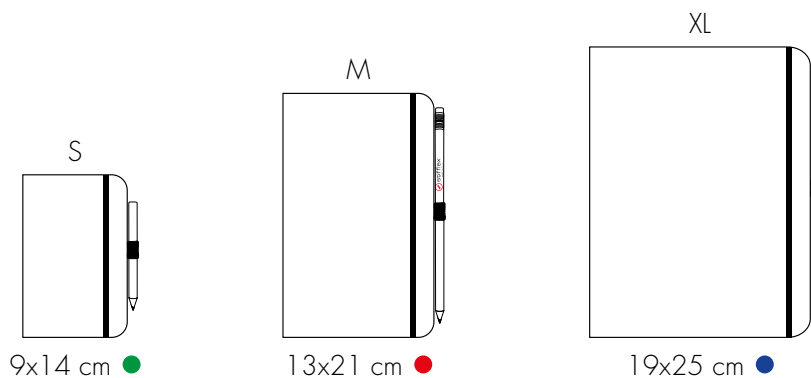

The notebooks in this collection are made with 80 g. uncoated white paper. They are available in the 9x14 cm, 13x21 cm, and 19x25 cm formats made up of 144 pages. Every notebook comes with a pencil and is FSC[®] certified.



BASIC

HARD COVER NOTEBOOK WITH PENCIL

BLACK



RED



BLUE



YELLOW



Ruled sheets



aR001S (9x14)
aR001M (13x21)
aR001XL (19x25)

aR002S (9x14)
aR002M (13x21)
aR002XL (19x25)

aR003S (9x14)
aR003M (13x21)
aR003XL (19x25)

aR004S (9x14)
aR004M (13x21)
aR004XL (19x25)

Blank sheets



bR001S (9x14)
bR001M (13x21)
bR001XL (19x25)

bR002S (9x14)
bR002M (13x21)
bR002XL (19x25)

bR003S (9x14)
bR003M (13x21)
bR003XL (19x25)

bR004S (9x14)
bR004M (13x21)
bR004XL (19x25)

LEATHERLIKE

HARD COVER NOTEBOOK WITH PENCIL

BLACK



BROWN



LIGHT BROWN



DOVE GREY



Ruled sheets



aR005M (13x21)

aR006M (13x21)

aR007M (13x21)

aR008M (13x21)

Blank sheets



bR005M (13x21)

bR006M (13x21)

bR007M (13x21)

bR008M (13x21)

From the shortening of the name *Stifflex* come the new collection of **Flex** notebooks that are characterized by a flexible softcover in monochromatic shades that hold lined, blank, and squared pages in ivory paper inside. Available in six different pastel colors, the notebooks in this collection have a subdued and appealing look adapting themselves perfectly to brightening your day with a touch of originality.

FORMAT

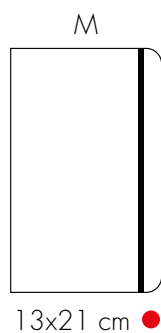

The notebook is made with uncoated 80 gram ivory paper. It's available in the 13x21 cm format and composed of 192 pages of which 144 are lined, 32 are blank, and 16 are squared. The squared pages are perforated and can be easily detached. The product is FSC[®] certified.



FLEX

SOFTCOVER NOTEBOOK

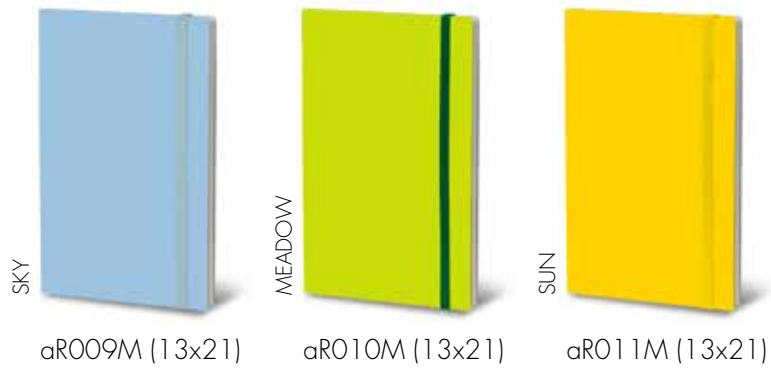

FLEX

SOFTCOVER NOTEBOOK

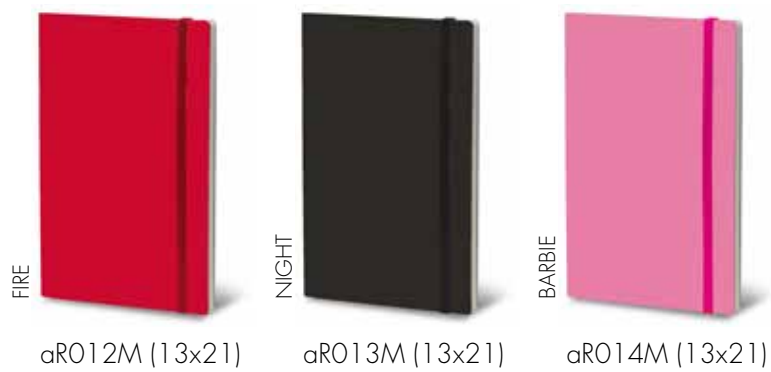

PRISMA

Colors

Practical, versatile and colorful: this is the notebook from the new *PRISMA Colors* collection that distinguishes itself for the variety of its colors. The soft and flexible cover in textured card stock is available in vivacious monochrome colors in acid free ivory paper and made to adapt itself to every kind of writing instrument.

FORMATS

Available in 12 different colors in two formats, 8,5 x 12,5 cm and 17 x 24 cm. They are perfect to lighten up your day, practical to take notes on at work or at school ... choose your favorite color to always bring with you!

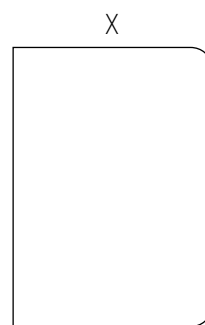

17x24 cm ●



8,5x12,5 cm ●

BOX

Collect all of them in a practical box-display available in the Black or Words version.



WHITE DISPLAY: WORDS

Measurements: cm 12x17x25h
Contains: 12 pieces 17x24 cm



BLACK DISPLAY: BLACK

Measurements: cm 12x17x25h
Contains: 12 pieces 17x24 cm



Complete assortment 24 PIECES

Measurements: cm 10x18x13h
Contains: 24 pieces 8,5x12,5 cm



PRISMA COLORS

JOURNAL FOR NOTES

ruled sheets ruled sheets blank sheets blank sheets

Charlie BROWN The Woman in RED The GOLD Rush The PINK Panther

PXR01 (17x24) PXR04 (17x24) PXR02 (17x24) PXR03 (17x24)
 PXS01 (8,5x12,5) PXS04 (8,5x12,5) PXS02 (8,5x12,5) PXS03 (8,5x12,5)

PRISMA COLORS

JOURNAL FOR NOTES

ruled sheets ruled sheets blank sheets blank sheets

A Clockwork ORANGE GREEN Book YELLOW Submarine Fried GREEN Tomatoes

PXR05 (17x24) PXR08 (17x24) PXR06 (17x24) PXR07 (17x24)
 PXS05 (8,5x12,5) PXS08 (8,5x12,5) PXS06 (8,5x12,5) PXS07 (8,5x12,5)

PRISMA COLORS

JOURNAL FOR NOTES

ruled sheets ruled sheets blank sheets blank sheets

The BLUE Lagoon BLACK or White Mickey BLUE Eyes Fifty Shades of GREY

PXR09 (17x24) PXR12 (17x24) PXR10 (17x24) PXR011 (17x24)
 PXS09 (8,5x12,5) PXS12 (8,5x12,5) PXS10 (8,5x12,5) PXS11 (8,5x12,5)

DRAW - COLOR - DESIGN

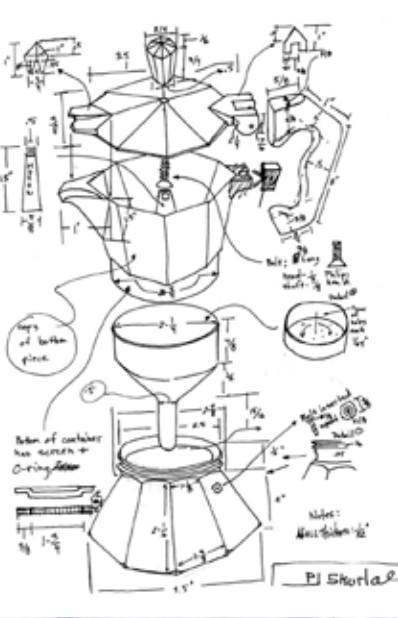

artWORK

The **artWORK** collection is a one-of-a-kind product that has been made to satisfy the professional and creative needs of those with a passion for art. Every detail comes from careful study and it is made using high-quality paper to satisfy the needs of students and artists. It's ideal to be used with different techniques from dry to wet, for markers or sketching. As in all the products that we make, even the *artWORK* line is produced with cellulose certified FSC® from forests managed according to rigorous environmental, social, and economic standards.

artWORK is made in three types:

artWORK book – Sewn bounded notebook with a hard cover and elastic closure,

rounded corners and can be opened at 180°. It's available in two formats: 15 x 21 cm and 19 x 25 cm.

artWORK pad – Spiral bound pad with microperforated sheets, a semi-hard cardboard cover and a thick, hard backboard. It's available in the versions: *Sketch, Draw, Paint, Watercolor, Marker, Manga, Pastel* in the 24 x 33 cm format.

artWORK block – The Classic drawing block with the sheets glued on the short side and a semi-hard back cover in cardstock. The cover is glued to the cardstock and separated from the sheets so as to be able to bend it to the back. Available in two versions: *Bristol Smooth* and *Bristol Rough* in the 21 x 29.7 cm format.

artWORK book

artWORK book is perfect for drafting sketches and designs in the studio or outside in the open. This notebook for sketches is made from high-quality paper that supports a wide range of artists' tools and offers an optimal resistance to erasers. Every *artWORK book* transforms itself into an archive of your works of art and has the following characteristics:

- 128 blank pages "SKETCH" in 160 gram paper, 32 dotted pages "DESIGN" in 120 gram paper, and 32 pages of semi-transparent pages "SHARED IDEAS" in 95 gram tracing paper that is perforated and detachable.

Developed for professionals and for anyone with a passion for art, *artWORK book* leaves space to observations and to the imagination to create sketches and designs from your world.

FORMATS

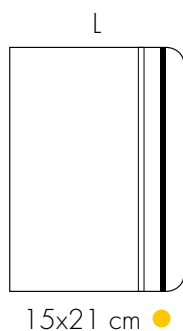

15x21 cm ●

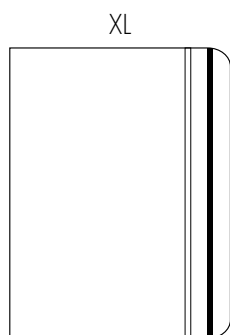

19x25 cm ●

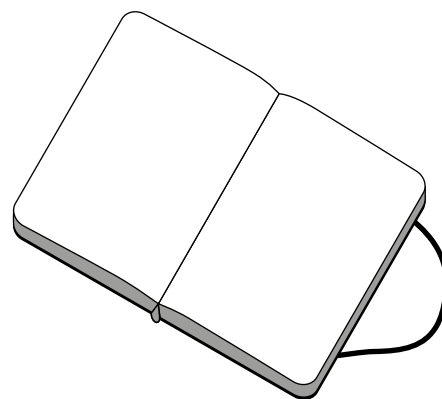

COMPLETELY OPENS

at 180°

DISPLAYS

Supplied already assembled, they are made in white alveolar cardboard, and painted with sprayed tempera in line with the standards of environmental sustainability and respect for the environment.



EXPO2M artWORK

Counter display (15x21 cm)

Measurements: cm 52x29x34h

Can contain: 24 pieces 15x21 cm



EXPO4 ML artWORK

Counter display (15x21 cm and 19x25 cm)

Measurements: cm 56x29x34h

Can contain: 16 pieces 15x21 cm and 8 pieces 19x25 cm



ARTWORK BOOK 15x21

NOTEBOOK FOR SKETCHES



COLOR SPLASH

212L (15x21)



NATURE SPLASH

213L (15x21)



TREVI FOUNTAIN

246L (15x21)



INTERIOR LIVING

247L (15x21)

ARTWORK BOOK 15x21

NOTEBOOK FOR SKETCHES

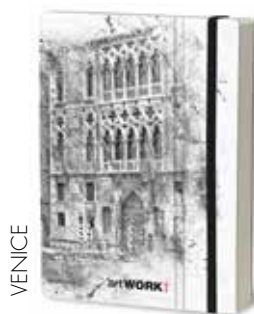

VENICE

216L (15x21)



LEONARDO

217L (15x21)



VAN GOGH

225L (15x21)



PICASSO

226L (15x21)

ARTWORK BOOK 15x21

NOTEBOOK FOR SKETCHES



HARING

248L (15x21)

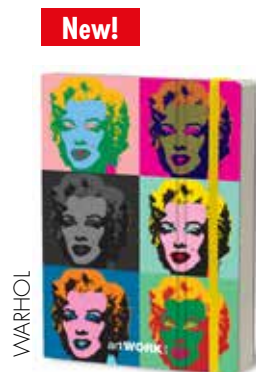

WARHOL

249L (15x21)



BASQUIAT

250L (15x21)

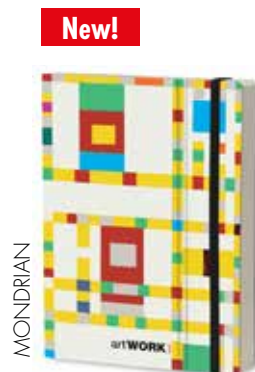

MONDRIAN

251L (15x21)

ARTWORK BOOK 15x21

NOTEBOOK FOR SKETCHES



ARTWORK BOOK 19x25

NOTEBOOK FOR SKETCHES



ARTWORK BOOK 19x25

NOTEBOOK FOR SKETCHES





artwork and photograph by Sebastian Łapot @sebastian_rysuję

artWORK pad

The new *artWORK pad* collection was developed to gather your ideas and projects in a practical solution. Made with the best raw materials that will give an added touch to your creativity.

SKETCH - DRAW - PAINT : Made with fine grain drawing paper (weight in grams 120/160/250) whose surface assures easy and repeated erasure and an excellent outcome of your work. Produced with pure cellulose, it's internally sized as well as on the surface and it is acid-free guaranteeing that it lasts over a long period of time.

WATERCOLOR : High-quality watercolor paper. It presents itself with a textured surface on both sides that allows it to be used on the front as well as on the back. Produced with the purest cellulose and 40% cotton, it's internally sized as well as on the surface assuring an optimal absorption of colors and the possibility of retouching by washing it with a brush or scraping. It is acid-free assuring a long preservation over time.

MARKER : Extra white and an ultra-smooth surface with matte finish specifically made for every type of marker including alcohol and solvent-based markers. It is also suitable for the use of graphite and colored pencils. The paper has a special barrier that prevents colors from passing through and it offers a vivid reproduction of the colors even after repeated use of the marker, sharp strokes, perfect flow of the marker and dries fast. Acid-free.

MANGA : The white paper has the same characteristics of the **MARKER** collection. The 10 sheets in colored paper in five shades allow for the creation of works with brilliant, pearlescent and iridescent surfaces that evoke a *Manga* style.

PASTEL : A special paper made for pastel techniques with a very rough surface that allows for the multiplication of layers of pigment with a saturation effect. It is suitable for energetic strokes as well as for soft shading. In addition, it maintains it's properties even after being wet or erased. It also supports wet techniques or alcohol without ruining the grain or the absorption of the surface. It is acid-free with a neutral pH that allows for the perfect preservation over time.

FORMAT

SPIRAL BOUND

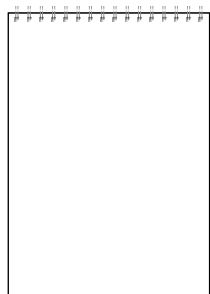

24x33 cm ●

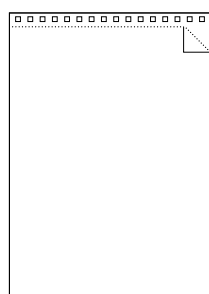

Microperforated

DISPLAY

Supplied already assembled, it is made in white alveolar cardboard, and painted with sprayed tempera in line with the standards of environmental sustainability and respect for the environment.



EXPO5 artWORK

Counter display (24x33 cm)

Measurements: cm 29x27x40h

Can contain: 12 pieces 24x33 cm



SKETCH

BEST FOR: GRAPHITE PENCIL - CHARCOAL - INK - MARKER - FELT-TIP PEN - COLORED PENCIL

SMOOTH SURFACE

120 g/m²

 x80 Sheets
Natural White

LEONARDO



APSO04 (24x33)

New!

RUBENS



APSO05 (24x33)

New!

RAFFAELLO



APSO06 (24x33)

New!

COLOSSEO





APSO07 (24x33)

DRAW

BEST FOR: MIXED MEDIA - GRAPHITE PENCIL - CHARCOAL - PASTEL - COLORED PENCIL - CRAYON - FOUNTAIN PEN - INK

SMOOTH SURFACE

160 g/m²

 x50 Sheets
Natural White
 x15 Sheets
Transparent

MICHELANGELO



APD003 (24x33)

New!

INTERIOR STUDIO



APD005 (24x33)

New!

MATISSE



APD006 (24x33)

New!

URBAN DRAW



APD007 (24x33)

PAINT

BEST FOR: MIXED MEDIA - GRAPHITE PENCIL - GOUACHE - WATERCOLOR - PASTEL - MARKER - FELT-TIP PEN

SMOOTH SURFACE

250 g/m²

 x30 Sheets
Natural White
+  x3 Sheets
Apricot
+  x3 Sheets
Light Blue
+  x3 Sheets
Light Gray
+  x3 Sheets
Black

BASQUIAT



APPO02 (24x33)

SCHIELE



APPO03 (24x33)

New!

COLOR CANVAS



APPO05 (24x33)

New!

ANGIOLETTI



APPO06 (24x33)

WATERCOLOR

BEST FOR: WATERCOLOR - INK - GOUACHE - GRAPHITE - CHARCOAL - WAX CRAYON - OIL PASTEL - TEXTURED SURFACE



TEXTURED SURFACE

300 g/m²

x20 Sheets
Natural White



APW001 (24x33)



APW002 (24x33)



APW003 (24x33)



APW004 (24x33)

MARKER

BEST FOR: MARKER - FELT-TIP PEN - SPRAY - GRAPHITE - PENCIL - PASTEL



ULTRA SMOOTH SURFACE

300 g/m²

x30 Sheets
Extra White



APMK001 (24x33)



APMK004 (24x33)



APMK005 (24x33)



APMK006 (24x33)

MANGA

BEST FOR: MARKER - FELT-TIP PEN - SPRAY - GRAPHITE - PENCIL - PASTEL



SMOOTH SURFACE

300 g/m²

- x20 Sheets Extra White
- + x2 Sheets White Pearl
- + x2 Sheets Cream Pearl
- + x2 Sheets Light Green Pearl
- + x2 Sheets Light Blue Pearl
- + x2 Sheets Pink Pearl



APMG001 (24x33)



APMG002 (24x33)



PASTEL - dark grey

BEST FOR: PASTELS -
COLORED PENCILS

VERY ROUGH
SURFACE

360 g/m²

 x16 Sheets
Dark Grey



RAFFAELLO

APGS001 (24x33)



CARAVAGGIO

APGS002 (24x33)

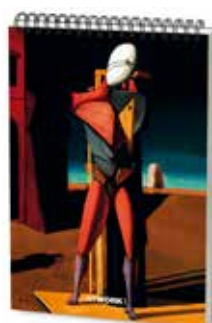

DE CHIRICO

APGS003 (24x33)

PASTEL - light shades

BEST FOR: PASTELS -
COLORED PENCILS

VERY ROUGH
SURFACE

360 g/m²

-  x16 Sheets
Light Shades
- +  x4 Sheets
Light Grey
- +  x4 Sheets
Light Blue
- +  x4 Sheets
Light Green
- +  x4 Sheets
Apricot



MONET

APTC001 (24x33)



KLIMT

APTC002 (24x33)



DEGAS

APTC003 (24x33)

PASTEL - dark shades

BEST FOR: PASTELS -
COLORED PENCILS

VERY ROUGH
SURFACE

360 g/m²

-  x16 Sheets
Dark Shades
- +  x4 Sheets
Dark Grey
- +  x4 Sheets
Dark Blue
- +  x4 Sheets
Dark Green
- +  x4 Sheets
Dark Red



BOTTICELLI

APTS001 (24x33)



DE NITTIS

APTS002 (24x33)

New!



VERMEER

APTS004 (24x33)

art**WORK** block

The *artWORK* collection expands with a new line called **artWORK block**.

Sheets glued on the short side that are easily detachable and a front and back cover in cardstock.

Available in two versions, BRISTOL SMOOTH and BRISTOL ROUGH with the following characteristics:

- BRISTOL SMOOTH, consisting of 50 natural white sheets of 200 grams. The paper has a smooth finish and is made of 35% cotton fibers that makes it ideal for techniques that require a smooth surface and precise strokes like from a pencil, pastels and crayons as well as wet techniques like gouache and watercolor.
- BRISTOL ROUGH, made of 50 sheets of 200 grams in pure virgin cellulose paper of the highest quality. The rough surface, the high level of brightness and the excellent resistance to light combined with a superior rigidity make it a product specifically for dry techniques like pencil, graphite, pastel as well as for wet techniques like watercolor and acrylic paint.

FORMAT

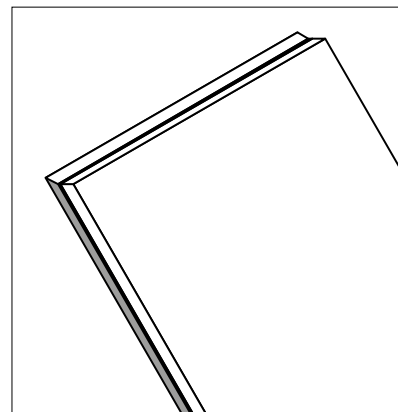
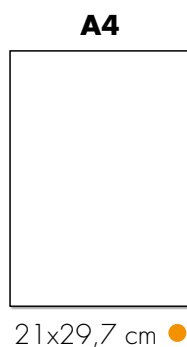

**GLUED ON THE
SHORT SIDE**



BRISTOL SMOOTH

BEST FOR: MIXED MEDIA - PENCIL - PASTEL -
WAX PASTELS - GOUACHE - WATERCOLOR

SMOOTH
SURFACE

200 g/m²

 x50 Sheets
Natural White

	New!	New!	New!	New!
URBAN TRAIN		ART MAKES PEOPLE POWERFUL		URBAN 2 CW
		CARAVAGGIO PORTRAIT		
	ABBLO01 (21x29,7)	ABBLO02 (21x29,7)	ABBLO03 (21x29,7)	ABBLO04 (21x29,7)

BRISTOL ROUGH

BEST FOR: MIXED MEDIA - PENCIL - GRAPHITE -
PASTEL - WATERCOLOR - ACRYLIC PAINT

ROUGH
SURFACE

200 g/m²

 x50 Sheets
Extra White

	New!	New!	New!	New!
BARBERINI		CHERUBINI		CENACOLO
		PARIS		
	ABBRO01 (21x29,7)	ABBRO02 (21x29,7)	ABBRO03 (21x29,7)	ABBRO04 (21x29,7)



**WHO DOESN'T LIKE
A BEAUTIFUL STORY?**

**THESE PLANNERS AND
NOTEBOOKS ARE PRINTED
ON PAPER THAT HELPS YOU
SAVE OUR FORESTS.**

**THIS WAY THERE WILL ALWAYS
BE BEAUTIFUL STORIES TO TELL.**

CHOOSE FSC®.



ECO-SUSTAINABILITY

Our company, for a few years now, has embarked on the road of eco-sustainability by choosing to make products with materials marked FSC® and that means they have been managed in a proper and responsible way according to rigorous environmental, social, and economic standards.

The Forest Stewardship Council® (or in short **FSC®**) is an international Non-Governmental Organization (NGO). FSC® has created a forest certification system that is recognized all over the world. The objective of the certification is the proper management of forests and the traceability of the products derived from them. The FSC® logo guarantees that the product is

made with raw materials derived from forests that are managed according to two principle standards: forest management and chain of custody. The FSC® certification diagram is independent and by third party. Inspections are done by over 30 certification entities around the world. The FSC® counts among its members a group of varied commercial entities, environmental organizations, and groups from civil society. It groups together NGOs, organizations that work in the social field, indigenous associations and academic institutions, researchers, and technical people who have manifested a commitment in favor of a socially ethical use of forest products.

www.fsc.org



**The mark of
responsible forest
management**

Made in Italy

3•6•5[®] Srl

Via Leonardo da Vinci 118/3
50028 Barberino Tavarnelle - Firenze - Italy
tel. +39 055 8070175 fax +39 055 8070129
info@mazzuoli.it

www.mazzuoli.it www.stifflex.it

follow us on:

